

1.尺寸 DIMENSION(mm)

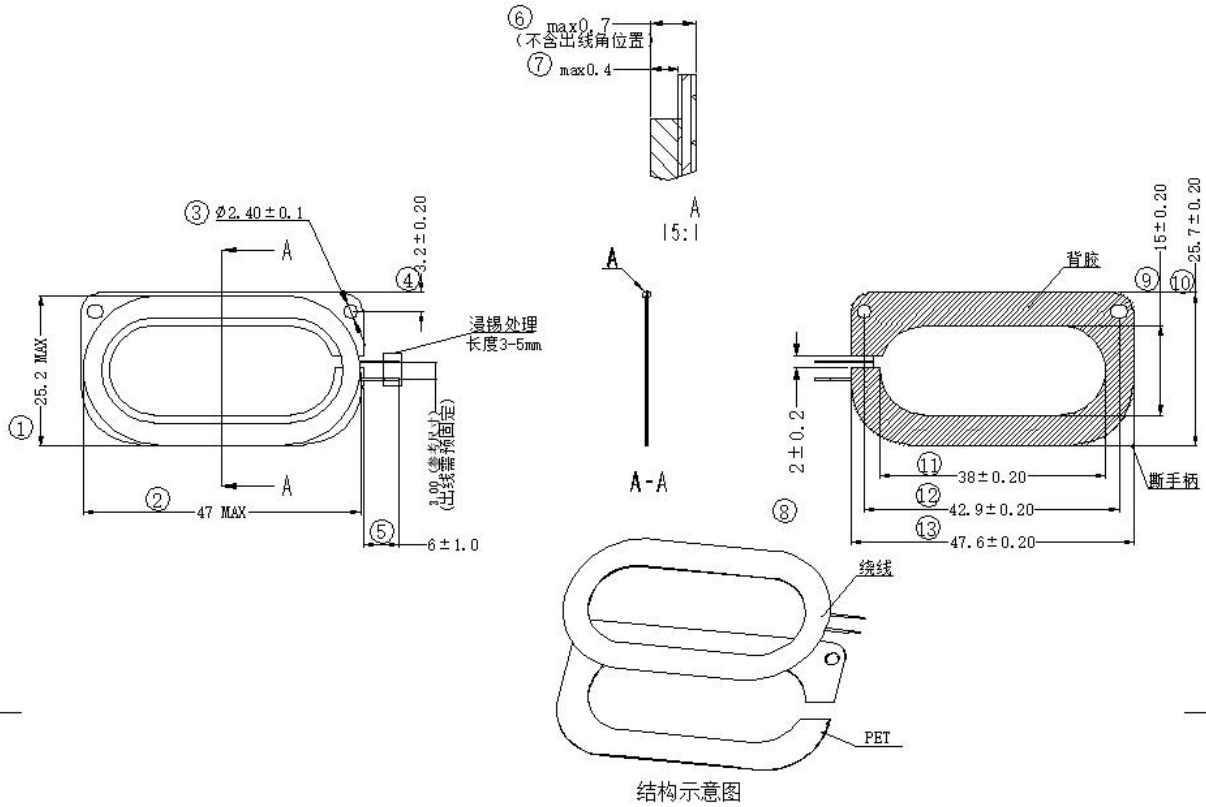

2. 原理图 SCHEMATIC DIAGRAM



3.绕线参数 Winding Specification

序号 NO.	线材规格 Material	圈数 Turns	绕线方向 Winding Direction
1	0.3 自粘漆包线	9Ts	CCW



技术参数

DM-RS4725A-01

technical parameter

4.电气特性 ELECTRICAL CHARACTERISTICS:

100KHz/1Vrms, 温度 TEMPERATURE:25±10°C, 湿度 RELATIVE HUMIDITY:65±20%

序号 No.	测试项目 Item	测量值 Specification	测试设备 Test Equipments
1	电感 Ls	5.6+/-2.5% uH	HIOKI 3536 LCR 测量仪
2	交流电阻 RS	310 mΩ MAX	HIOKI 3536 LCR 测量仪
3	直流电阻 DCR	290 mΩ MAX	HIOKI 3536 LCR 测量仪
4	Q 值	11.3 MIN	HIOKI 3536 LCR 测量仪
5	工作频率	110-140 kHz	